

# PK 44502

*High Performance*

**PALFINGER** CRANE

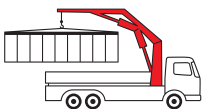

## Profitable heavy-duty crane technology

The PK 44502 with its maintenance-free extension boom system and Power Link Plus represents maximum profitability. Its double knuckle-boom system and 15 degree reverse linkage knuckle boom guarantee high lifting forces and outstanding motion geometry.

The double rack and pinion slewing system enables a high slewing moment with a simple construction.

- An advantage that pays dividends during container transports and loading heavy machinery.

A perfect combination  
of power  
and profitability

**PK 44502 High Performance**

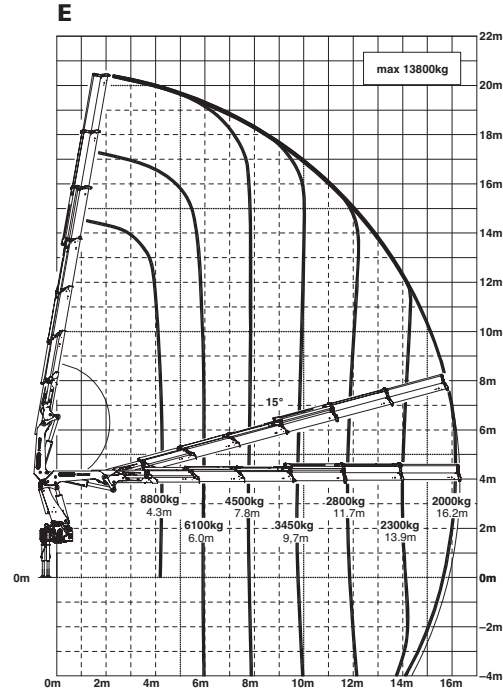
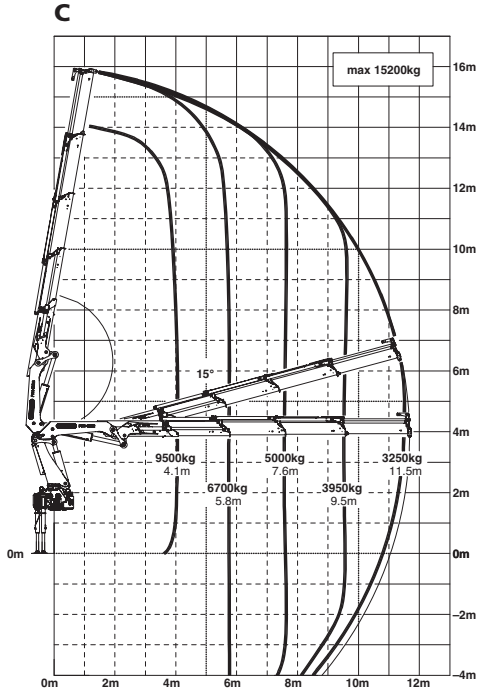

**Technical Specifications (EN 12999 HC1 HD4/B3)**

Max. lifting moment	41.9 mt/410.8 kNm
Max. lifting capacity	16600 kg/162.8 kN
Max. hydraulic outreach	16.3 m
Max. manual outreach	23.3 m
Slewing angle	400 °
Slewing torque	5.5 mt/54.0 kNm

Stabilizer spread (std.)	7.4 m
Fitting space required	min. 1.45 m/max. 1.59 m
Width folded	2.51 m
Max. operating pressure	320 bar
Recommended pump capacity	from 60 l/min to 80 l/min
Dead weight (std.)	4399 kg

